

## HIGH-BANDWIDTH DUAL SPDT DIFFERENTIAL SIGNAL SWITCH WITH INPUT LOGIC TRANSLATION

### FEATURES

- High-Bandwidth Data Paths – Up to 800 MHz
- Specified Break-Before-Make Switching
- Control Inputs Reference to  $V_{IO}$
- Low Charge Injection
- Excellent ON-State Resistance Matching
- Low Total Harmonic Distortion (THD)
- 2.3-V to 3.6-V Power Supply ( $V_+$ )
- 1.65-V to 1.95-V Logic Supply ( $V_{IO}$ )
- Latch-Up Performance Exceeds 100 mA Per JESD 78, Class II
- ESD Performance Tested Per JESD 22
  - 4000-V Human-Body Model (A114-B, Class II)
  - 1000-V Charged-Device Model (C101)
  - 200-V Machine Model (A115-A)

### APPLICATIONS

- Cell Phones
- PDAs
- Portable Instrumentation
- Low-Voltage Differential Signal Routing
- Mobile Industry Processor Interface (MIPI) Signal Routing

YZP PACKAGE  
(BOTTOM VIEW)

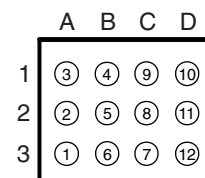

**TERMINAL ASSIGNMENTS**

	A	B	C	D
<b>1</b>	IN1	NO1	COM1	NC1
<b>2</b>	$V_{IO}$	GND	GND	$V_+$
<b>3</b>	IN2	NO2	COM2	NC2

### DESCRIPTION/ORDERING INFORMATION

The TS3DS26227 is a dual single-pole double-throw (SPDT) analog switch that is designed to operate from 2.3 V to 3.6 V. The device offers high-bandwidth data paths, and a break-before-make feature to prevent signal distortion during the transferring of a signal from one path to another. The device has excellent total harmonic distortion (THD) performance and consumes very low power. These features make this device suitable for portable applications.

The TS3DS26227 has a separate logic supply pin ( $V_{IO}$ ) that operates from 1.65 V to 1.95 V.  $V_{IO}$  powers the control circuitry, which allows the TS3DS26227 to be controlled by 1.8-V signals.

### ORDERING INFORMATION

$T_A$	PACKAGE <sup>(1)(2)</sup>	ORDERABLE PART NUMBER	TOP-SIDE MARKING <sup>(3)</sup>
–40°C to 85°C	NanoFree™ – WCSP (DSBGA) 0.23-mm Large Bump – YZP (Pb-free)	Tape and reel TS3DS26227YZPR	

- (1) Package drawings, thermal data, and symbolization are available at [www.ti.com/packaging](http://www.ti.com/packaging).
- (2) For the most current package and ordering information, see the Package Option Addendum at the end of this document, or see the TI website at [www.ti.com](http://www.ti.com).
- (3) YZP: The actual top-side marking has three preceding characters to denote year, month, and sequence code, and one following character to designate the assembly/test site. Pin 1 identifier indicates solder-bump composition (1 = SnPb, • = Pb-free).



Please be aware that an important notice concerning availability, standard warranty, and use in critical applications of Texas Instruments semiconductor products and disclaimers thereto appears at the end of this data sheet.

NanoFree is a trademark of Texas Instruments.

**SUMMARY OF CHARACTERISTICS<sup>(1)</sup>**

Configuration	Dual 2:1 Multiplexer/Demultiplexer (2 × SPDT)
Number of channels	2
ON-state resistance ( $r_{on}$ )	5 $\Omega$ max
ON-state resistance match ( $\Delta r_{on}$ )	0.1 $\Omega$ max
ON-state resistance flatness [ $r_{on(Flat)}$ ]	3 $\Omega$ max
Turn-on/turn-off time ( $t_{ON}/t_{OFF}$ )	9 ns/4 ns
Break-before-make time ( $t_{BBM}$ )	8 ns
Charge injection ( $Q_C$ )	5.5 pC
Bandwidth (BW)	800 MHz
OFF isolation ( $O_{ISO}$ )	–40 dB
Crosstalk ( $X_{TALK}$ )	–39 dB
Leakage current [ $I_{NO(OFF)}/I_{NC(OFF)}$ ]	$\pm 5$ nA
Power-supply current ( $I_+$ )	$\pm 20$ nA
Package options	12-bump WCSP

(1)  $V_+ = 2.7$  V,  $T_A = 25^\circ\text{C}$ **FUNCTION TABLE**

IN	NC TO COM, COM TO NC	NO TO COM, COM TO NO
L	ON	OFF
H	OFF	ON

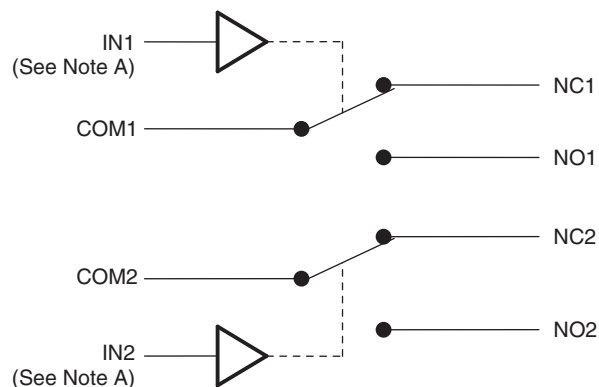
**LOGIC DIAGRAM**A. IN1 and IN2 are control inputs referenced to  $V_{IO}$ .

**ABSOLUTE MAXIMUM RATINGS<sup>(1)(2)</sup>**

over operating free-air temperature range (unless otherwise noted)

		MIN	MAX	UNIT
$V_+$ $V_{IO}$	Supply voltage range <sup>(3)</sup>	-0.5	4.6	V
$V_{NC}$ $V_{NO}$ $V_{COM}$	Analog voltage range <sup>(3)(4)(5)</sup>	-0.5	$V_+ + 0.5$	V
$I_K$	Analog port diode current	$V_{NC}, V_{NO}, V_{COM} < 0$ , or $V_{NC}, V_{NO}, V_{COM} > V_+ + 0.5$		mA
$I_{NC}$ $I_{NO}$ $I_{COM}$	On-state switch current	$V_{NC}, V_{NO}, V_{COM} = 0$ to $V_+$		mA
	On-state peak switch current	-100	100	
$V_I$	Digital input voltage range	-0.5	$V_{IO} + 0.5$	V
$I_{IK}$	Digital input clamp current <sup>(3)(4)</sup>	$V_I < 0$ , or $V_I > V_{IO} + 0.5$		mA
$I_+$	Continuous current through $V_+$	-100	100	mA
$I_{GND}$	Continuous current through GND	-100	100	mA
$\theta_{JA}$	Package thermal impedance <sup>(6)</sup>	YZP package		TBD °C/W
$T_{stg}$	Storage temperature range	-65	150	°C

- (1) Stresses above these ratings may cause permanent damage. Exposure to absolute maximum conditions for extended periods may degrade device reliability. These are stress ratings only, and functional operation of the device at these or any other conditions beyond those specified is not implied.
- (2) The algebraic convention, whereby the most negative value is a minimum and the most positive value is a maximum
- (3) All voltages are with respect to ground, unless otherwise specified.
- (4) The input and output voltage ratings may be exceeded if the input and output clamp-current ratings are observed.
- (5) This value is limited to 5.5 V maximum.
- (6) The package thermal impedance is calculated in accordance with JESD 51-7.

**ELECTRICAL CHARACTERISTICS FOR 3.3-V SUPPLY<sup>(1)</sup>**
 $V_+ = 2.7 \text{ V to } 3.6 \text{ V}$ ,  $V_{IO} = 1.65 \text{ V to } 1.95 \text{ V}$ ,  $T_A = -40^\circ\text{C to } 85^\circ\text{C}$  (unless otherwise noted)

PARAMETER	SYMBOL	TEST CONDITIONS	$T_A$	$V_+$	MIN	TYP	MAX	UNIT
<b>Analog Switch</b>								
Analog signal range	$V_{COM}, V_{NO}, V_{NC}$				0		$V_+$	V
ON-state resistance	$r_{on}$	$0 \leq (V_{NO} \text{ or } V_{NC}) \leq 1.6$ , $I_{COM} = -10 \text{ mA}$ , Switch ON, See <a href="#">Figure 13</a>	25°C Full	2.7 V		3.5	5	$\Omega$
ON-state resistance match between channels	$\Delta r_{on}$	$V_{NO} \text{ or } V_{NC} = 1.6 \text{ V}$ , $I_{COM} = -10 \text{ mA}$ , Switch ON, See <a href="#">Figure 13</a>	25°C Full	2.7 V		0.05	0.1	$\Omega$
ON-state resistance flatness	$r_{on(Flat)}$	$0 \leq (V_{NO} \text{ or } V_{NC}) \leq 1.6 \text{ V}$ , $I_{COM} = -10 \text{ mA}$ , Switch ON, See <a href="#">Figure 13</a>	25°C Full	2.7 V		2	3	$\Omega$
NC, NO OFF leakage current	$I_{NO(OFF)}, I_{NC(OFF)}$	$V_{NO} \text{ or } V_{NC} = 0.3 \text{ V}$ , $V_{COM} = 3 \text{ V}$ , or $V_{NO} \text{ or } V_{NC} = 3 \text{ V}$ , $V_{COM} = 0.3 \text{ V}$ , Switch OFF, See <a href="#">Figure 14</a>	25°C Full	3.6 V	-5	0.1	5	nA
NC, NO ON leakage current	$I_{NO(ON)}, I_{NC(ON)}$	$V_{NO} \text{ or } V_{NC} = 0.3 \text{ V}$ , $V_{COM} = \text{Open}$ , or $V_{NO} \text{ or } V_{NC} = 3 \text{ V}$ , $V_{COM} = \text{Open}$ , Switch ON, See <a href="#">Figure 15</a>	25°C Full	3.6 V	-10	0.2	10	nA
COM ON leakage current	$I_{COM(ON)}$	$V_{NO} \text{ or } V_{NC} = \text{Open}$ , $V_{COM} = 0.3 \text{ V}$ , or $V_{NO} \text{ or } V_{NC} = \text{Open}$ , $V_{COM} = 3 \text{ V}$ , Switch ON, See <a href="#">Figure 15</a>	25°C Full	3.6 V	-10	0.2	10	nA
<b>Digital Control Inputs (IN1, IN2)<sup>(2)</sup></b>								
Input logic high	$V_{IH}$	$V_{IO} = 1.65 \text{ V to } 1.95 \text{ V}$	Full		$0.65 \times V_{IO}$		$V_{IO}$	V
Input logic low	$V_{IL}$	$V_{IO} = 1.65 \text{ V to } 1.95 \text{ V}$	Full		0		$0.35 \times V_{IO}$	V
Input leakage current	$I_{IH}, I_{IL}$	$V_{IN} = V_{IO} \text{ or } 0$	25°C Full	3.6 V	-2	0.1	2	nA
					-10		10	

(1) The algebraic convention, whereby the most negative value is a minimum and the most positive value is a maximum

(2) All unused digital inputs of the device must be held at  $V_{IO}$  or GND to ensure proper device operation. Refer to the TI application report, *Implications of Slow or Floating CMOS Inputs*, literature number SCBA004.

**ELECTRICAL CHARACTERISTICS FOR 3.3-V SUPPLY (continued)**
 $V_+ = 2.7\text{ V to }3.6\text{ V}$ ,  $V_{IO} = 1.65\text{ V to }1.95\text{ V}$ ,  $T_A = -40^\circ\text{C to }85^\circ\text{C}$  (unless otherwise noted)

PARAMETER	SYMBOL	TEST CONDITIONS	$T_A$	$V_+$	MIN	TYP	MAX	UNIT	
<b>Dynamic</b>									
Turn-on time	$t_{ON}$	$V_{COM} = V_+$ , $R_L = 50\ \Omega$ ,	$C_L = 35\text{ pF}$ , See <a href="#">Figure 17</a>	25°C	3.3 V	1	6.5	9	ns
				Full	2.7 to 3.6 V	1		11.5	
Turn-off time	$t_{OFF}$	$V_{COM} = V_+$ , $R_L = 50\ \Omega$ ,	$C_L = 35\text{ pF}$ See <a href="#">Figure 17</a>	25°C	3.3 V	1	2	4	ns
				Full	2.7 to 3.6 V	1		5	
Break-before-make time	$t_{BBM}$	$V_{NC} = V_{NO} = 0.6\text{ V}$ , $R_L = 50\ \Omega$ ,	$C_L = 35\text{ pF}$ See <a href="#">Figure 18</a>	25°C	3.3 V	0.5	4	8	ns
				Full	2.7 to 3.6 V	0.5		9	
Charge injection	$Q_C$	$V_{GEN} = 0$ , $R_{GEN} = 0$ ,	$C_L = 1\text{ nF}$ See <a href="#">Figure 22</a>	25°C	3.3 V		5.5	pC	
NC, NO OFF capacitance	$C_{NC(OFF)}$ , $C_{NO(OFF)}$	$V_{NC}$ or $V_{NO} = 1.3\text{ V}$ or GND, Switch OFF,	See <a href="#">Figure 16</a>	25°C	3.3 V		3.5	pF	
NC, NO ON capacitance	$C_{NC(ON)}$ , $C_{NO(ON)}$	$V_{NC}$ or $V_{NO} = 1.3\text{ V}$ or GND, Switch ON,	See <a href="#">Figure 16</a>	25°C	3.3 V		10.5	pF	
COM ON capacitance	$C_{COM(ON)}$	$V_{COM} = 1.3\text{ V}$ or GND, Switch ON,	See <a href="#">Figure 16</a>	25°C	3.3 V		10.5	pF	
Digital input capacitance	$C_I$	$V_I = V_+$ or GND	See <a href="#">Figure 16</a>	25°C	3.3 V		2	pF	
Bandwidth	BW	$R_L = 50\ \Omega$ ,	Switch ON See <a href="#">Figure 19</a>	25°C	2.7 V		800	MHz	
OFF isolation	$O_{ISO}$	$R_L = 50\ \Omega$ , $f = 200\text{ MHz}$ ,	Switch OFF See <a href="#">Figure 20</a>	25°C	2.7 V		-40	dB	
Crosstalk	$X_{TALK}$	$R_L = 50\ \Omega$ , $f = 200\text{ MHz}$ ,	Switch ON See <a href="#">Figure 21</a>	25°C	2.7 V		-39	dB	
<b>Supply</b>									
Positive supply current	$I_+$	$V_I = V_+$ or GND,	Switch ON or OFF	25°C	3.6 V	-20	1	20	nA
				Full			-500		
Logic supply current	$I_{IO}$	$V_I = V_{IO}$ or GND,	Switch ON or OFF	25°C	3.6 V	-10	1	10	nA
				Full			-200		

**ELECTRICAL CHARACTERISTICS FOR 2.5-V SUPPLY<sup>(1)</sup>**
 $V_+ = 2.3 \text{ V to } 2.7 \text{ V}$ ,  $V_{IO} = 1.65 \text{ V to } 1.95 \text{ V}$ ,  $T_A = -40^\circ\text{C to } 85^\circ\text{C}$  (unless otherwise noted)

PARAMETER	SYMBOL	TEST CONDITIONS	$T_A$	$V_+$	MIN	TYP	MAX	UNIT
<b>Analog Switch</b>								
Analog signal range	$V_{COM}$ , $V_{NO}$ , $V_{NC}$				0		$V_+$	V
ON-state resistance	$r_{on}$	$0 \leq (V_{NO} \text{ or } V_{NC}) \leq 1.3$ , $I_{COM} = -10 \text{ mA}$ , Switch ON, See Figure 13	25°C Full	2.3 V		4	5.5 7	$\Omega$
ON-state resistance match between channels	$\Delta r_{on}$	$V_{NO} \text{ or } V_{NC} = 1.3 \text{ V}$ , $I_{COM} = -10 \text{ mA}$ , Switch ON, See Figure 13	25°C Full	2.3 V		0.05	0.1 0.2	$\Omega$
ON-state resistance flatness	$r_{on(Flat)}$	$0 \leq (V_{NO} \text{ or } V_{NC}) \leq 1.3 \text{ V}$ , $I_{COM} = -10 \text{ mA}$ , Switch ON, See Figure 13	25°C Full	2.3 V		2.5	4 4.5	$\Omega$
NC, NO OFF leakage current	$I_{NO(OFF)}$ , $I_{NC(OFF)}$	$V_{NO} \text{ or } V_{NC} = 0.2 \text{ V}$ , $V_{COM} = 2.3 \text{ V}$ , or $V_{NO} \text{ or } V_{NC} = 2.3 \text{ V}$ , $V_{COM} = 0.2 \text{ V}$ , Switch OFF, See Figure 14	25°C Full	2.7 V	-5 -15	0.1	5 15	nA
NC, NO ON leakage current	$I_{NO(ON)}$ , $I_{NC(ON)}$	$V_{NO} \text{ or } V_{NC} = 0.2 \text{ V}$ , $V_{COM} = \text{Open}$ , or $V_{NO} \text{ or } V_{NC} = 2.3 \text{ V}$ , $V_{COM} = \text{Open}$ , Switch ON, See Figure 15	25°C Full	2.7 V	-5 -20	0.2	5 20	nA
COM ON leakage current	$I_{COM(ON)}$	$V_{NO} \text{ or } V_{NC} = \text{Open}$ , $V_{COM} = 0.2 \text{ V}$ , or $V_{NO} \text{ or } V_{NC} = \text{Open}$ , $V_{COM} = 2.3 \text{ V}$ , Switch ON, See Figure 15	25°C Full	2.7 V	-1 -10	0.05	1 10	nA
<b>Digital Control Inputs (IN1, IN2)<sup>(2)</sup></b>								
Input logic high	$V_{IH}$	$V_{IO} = 1.65 \text{ V to } 1.95 \text{ V}$	Full		$0.65 \times V_{IO}$		$V_{IO}$	V
Input logic low	$V_{IL}$	$V_{IO} = 1.65 \text{ V to } 1.95 \text{ V}$	Full		0	$0.35 \times V_{IO}$		V
Input leakage current	$I_{IH}$ , $I_{IL}$	$V_{IN} = V_{IO} \text{ or } 0$	25°C Full	2.7 V	-1 -10	0.05	1 10	nA

(1) The algebraic convention, whereby the most negative value is a minimum and the most positive value is a maximum

(2) All unused digital inputs of the device must be held at  $V_{IO}$  or GND to ensure proper device operation. Refer to the TI application report, *Implications of Slow or Floating CMOS Inputs*, literature number SCBA004.

**ELECTRICAL CHARACTERISTICS FOR 2.5-V SUPPLY (continued)**
 $V_+ = 2.3 \text{ V to } 2.7 \text{ V}$ ,  $V_{IO} = 1.65 \text{ V to } 1.95 \text{ V}$ ,  $T_A = -40^\circ\text{C to } 85^\circ\text{C}$  (unless otherwise noted)

PARAMETER	SYMBOL	TEST CONDITIONS	$T_A$	$V_+$	MIN	TYP	MAX	UNIT	
<b>Dynamic</b>									
Turn-on time	$t_{ON}$	$V_{COM} = V_+$ , $R_L = 50 \Omega$ ,	$C_L = 35 \text{ pF}$ See <a href="#">Figure 17</a>	25°C	2.5 V	1	7	11	ns
				Full	2.3 to 2.7 V	1		13	
Turn-off time	$t_{OFF}$	$V_{COM} = V_+$ , $R_L = 50 \Omega$ ,	$C_L = 35 \text{ pF}$ See <a href="#">Figure 17</a>	25°C	2.5 V	1	2.5	4.5	ns
				Full	2.3 to 2.7 V	1		5.5	
Break-before-make time	$t_{BBM}$	$V_{NC} = V_{NO} = 0.6 \text{ V}$ , $R_L = 50 \Omega$ ,	$C_L = 35 \text{ pF}$ See <a href="#">Figure 18</a>	25°C	2.3 V	1	4	8	ns
				Full	2.3 to 2.7 V	1		10	
Charge injection	$Q_C$	$V_{GEN} = 0$ , $R_{GEN} = 0$ ,	$C_L = 1 \text{ nF}$ See <a href="#">Figure 22</a>	25°C	2.5 V		4	pC	
NC, NO OFF capacitance	$C_{NC(OFF)}$ , $C_{NO(OFF)}$	$V_{NC}$ or $V_{NO} = 1.6 \text{ V}$ or GND, Switch OFF,	See <a href="#">Figure 16</a>	25°C	2.5 V		3.5	pF	
NC, NO ON capacitance	$C_{NC(ON)}$ , $C_{NO(ON)}$	$V_{NC}$ or $V_{NO} = 1.6 \text{ V}$ or GND, Switch ON,	See <a href="#">Figure 16</a>	25°C	2.5 V		10.5	pF	
COM ON capacitance	$C_{COM(ON)}$	$V_{COM} = 1.6 \text{ V}$ or GND, Switch ON,	See <a href="#">Figure 16</a>	25°C	2.5 V		10.5	pF	
Digital input capacitance	$C_I$	$V_I = V_+$ or GND	See <a href="#">Figure 16</a>	25°C	2.5 V		2	pF	
Bandwidth	BW	$R_L = 50 \Omega$ ,	Switch ON See <a href="#">Figure 19</a>	25°C	2.3 V		800	MHz	
OFF isolation	$O_{ISO}$	$R_L = 50 \Omega$ , $f = 200 \text{ MHz}$ ,	Switch OFF See <a href="#">Figure 20</a>	25°C	2.3 V		-40	dB	
Crosstalk	$X_{TALK}$	$R_L = 50 \Omega$ , $f = 200 \text{ MHz}$ ,	Switch ON See <a href="#">Figure 21</a>	25°C	2.3 V		-39	dB	
<b>Supply</b>									
Positive supply current	$I_+$	$V_I = V_+$ or GND,	Switch ON or OFF	25°C	2.7 V	-10	1	10	nA
				Full				350	
Logic supply current	$I_{IO}$	$V_I = V_{IO}$ or GND,	Switch ON or OFF	25°C	2.7 V	-5	1	5	nA
				Full				-200	

TYPICAL CHARACTERISTICS

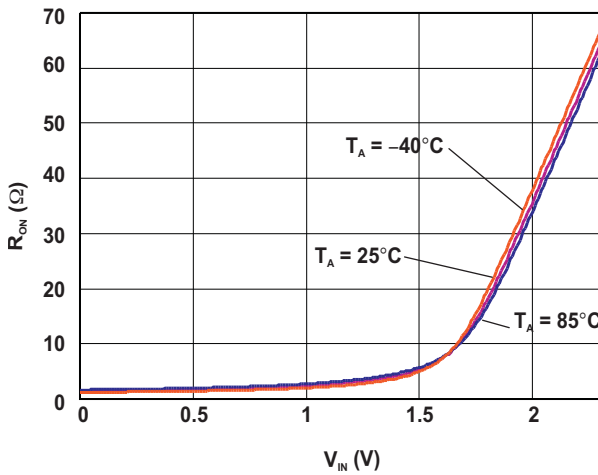

Figure 1.  $r_{on}$  vs  $V_I$  (NC, NO, or COM),  $V_+ = 2.3$  V

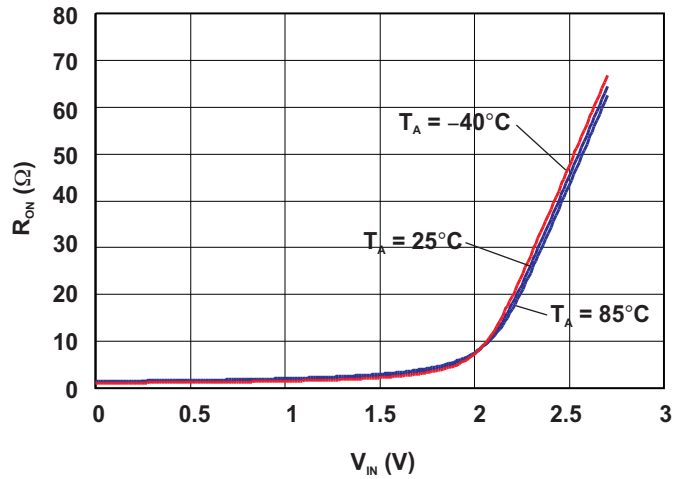

Figure 2.  $r_{on}$  vs  $V_I$  (NC, NO, or COM),  $V_+ = 2.7$  V

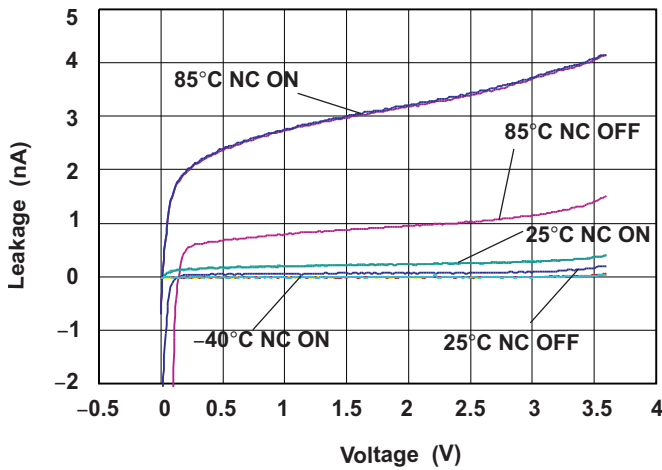

Figure 3. Analog Switch Leakage Current vs  $V_I$  (NC, NO, or COM),  $V_+ = 3.6$  V

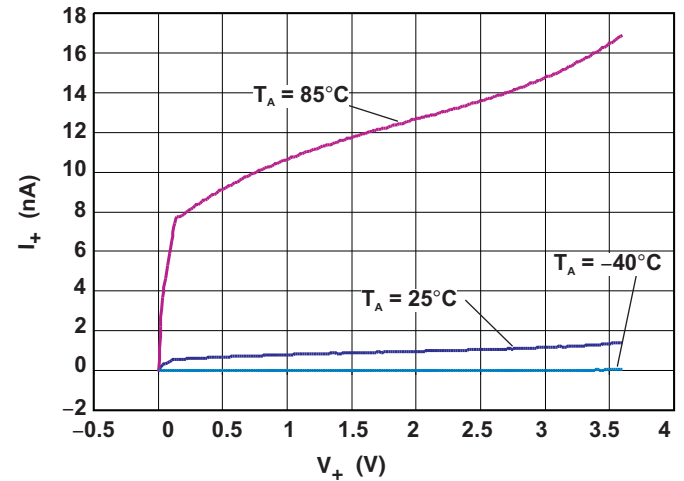

Figure 4.  $I_+$  Supply Current vs  $V_+$

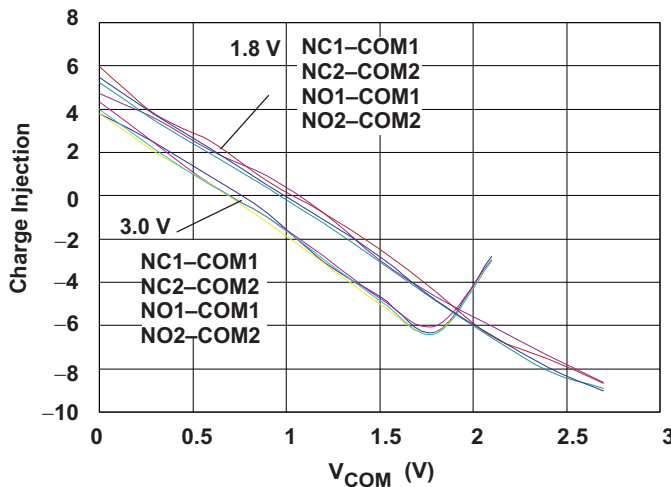

Figure 5. Charge Injection vs  $V_{COM}$

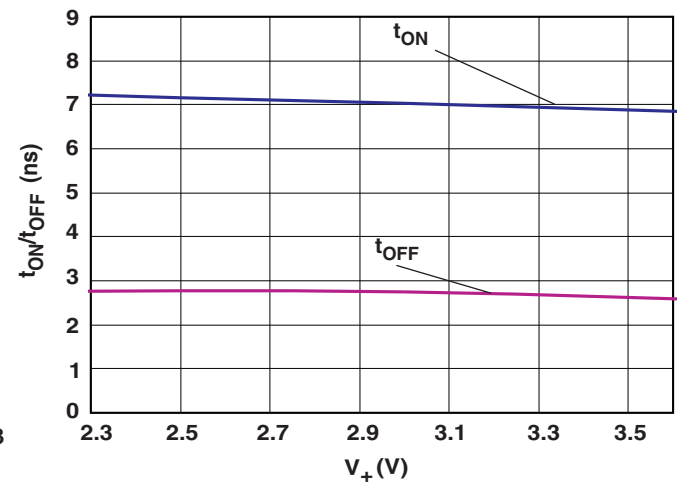

Figure 6.  $t_{on}/t_{off}$  vs  $V_+$



TYPICAL CHARACTERISTICS (continued)

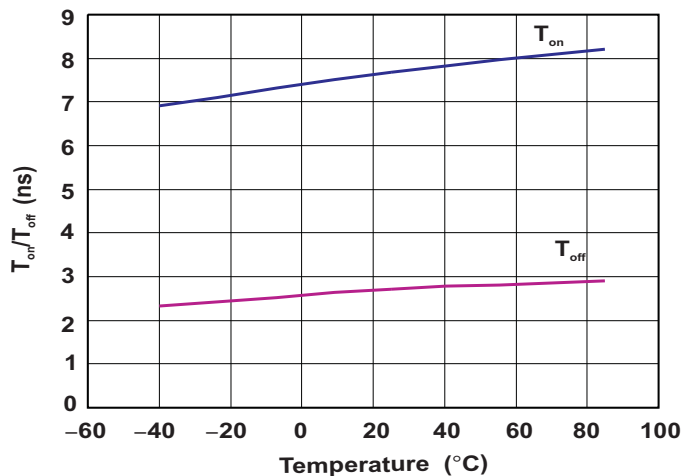

Figure 7.  $t_{on}/t_{off}$  vs Temperature,  $V_+ = 2.3$  V

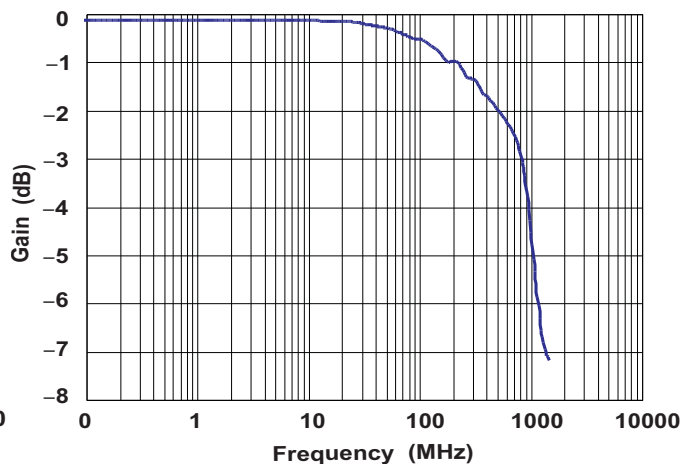

Figure 8. Bandwidth,  $V_+ = 2.5$  V

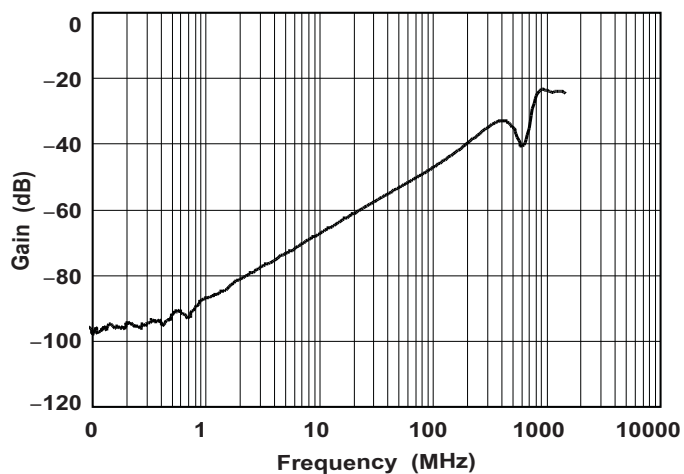

Figure 9. OFF Isolation vs Frequency,  $V_+ = 2.5$  V

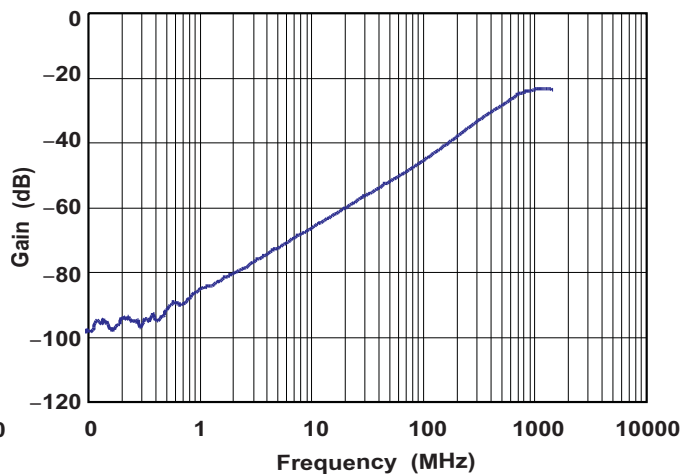

Figure 10. Crosstalk vs Frequency,  $V_+ = 2.5$  V

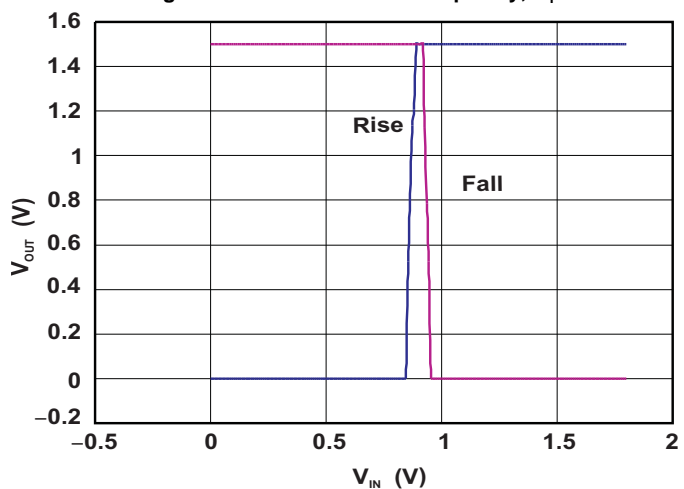

Figure 11. Threshold Voltage,  $V_{IO} = 1.8$  V,  $V_+ = 2.7$  V

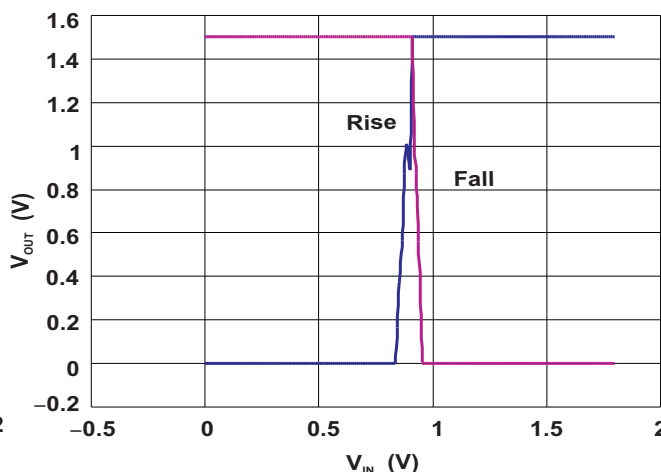

Figure 12. Threshold Voltage,  $V_{IO} = 1.8$  V,  $V_+ = 3.6$  V

PARAMETER MEASUREMENT INFORMATION

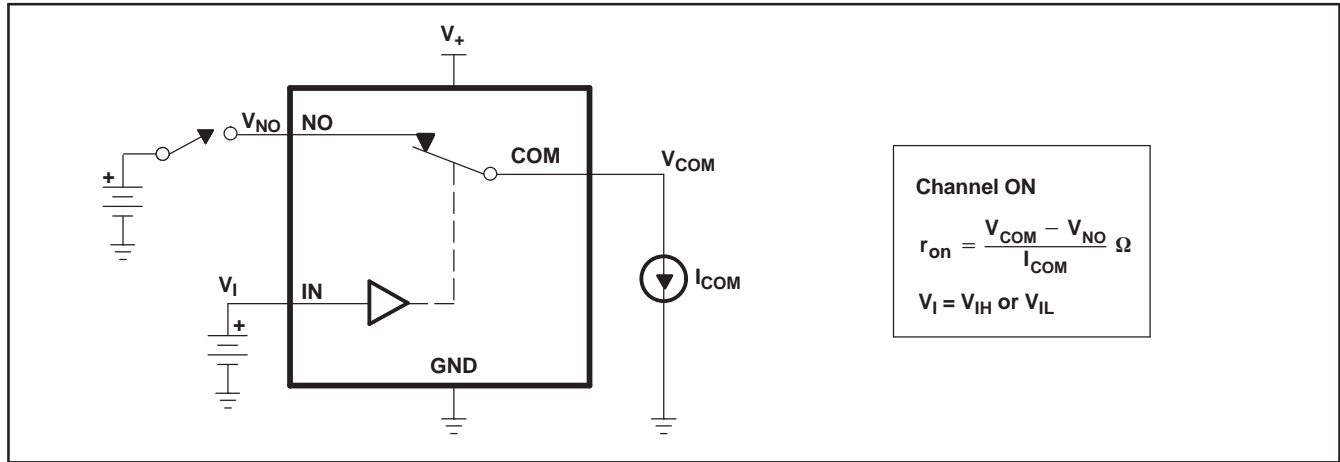

Figure 13. ON-State Resistance ( $r_{on}$ )

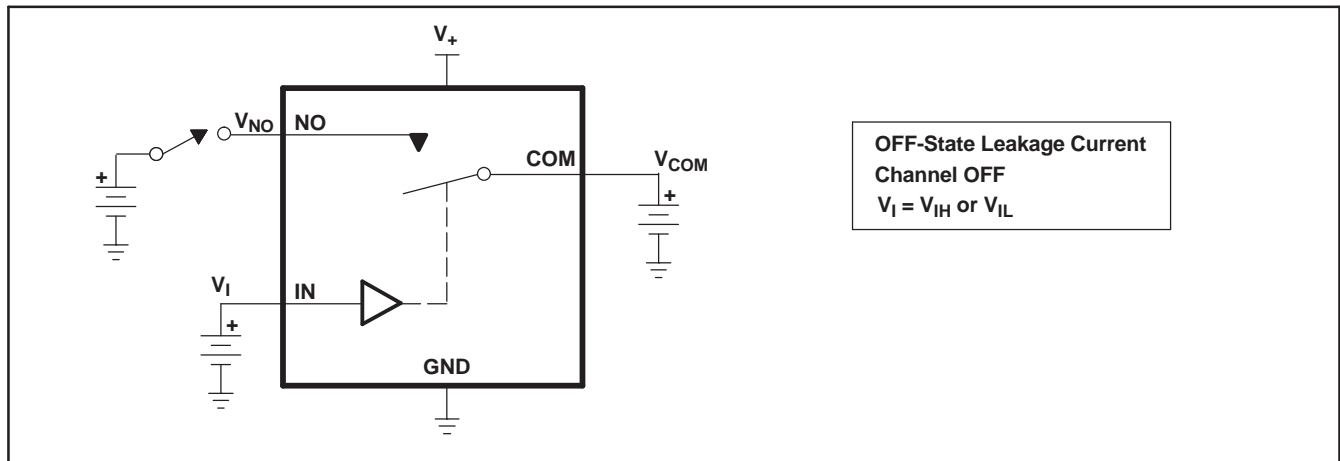

Figure 14. OFF-State Leakage Current ( $I_{COM(OFF)}$ ,  $I_{NC(OFF)}$ ,  $I_{COM(PWROFF)}$ ,  $I_{NC(PWROFF)}$ )

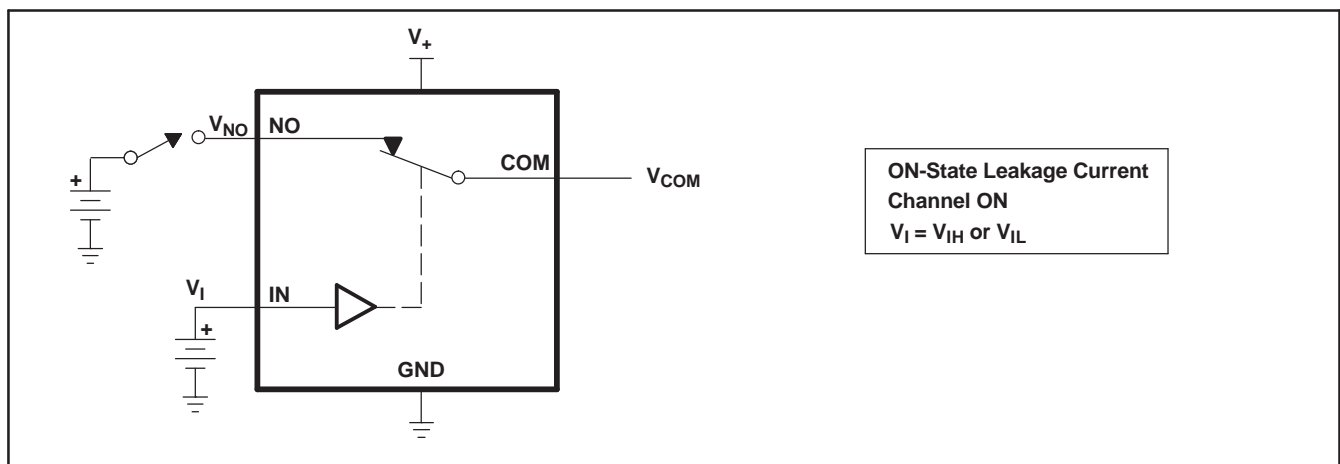

Figure 15. ON-State Leakage Current ( $I_{COM(ON)}$ ,  $I_{NC(ON)}$ )

PARAMETER MEASUREMENT INFORMATION (continued)

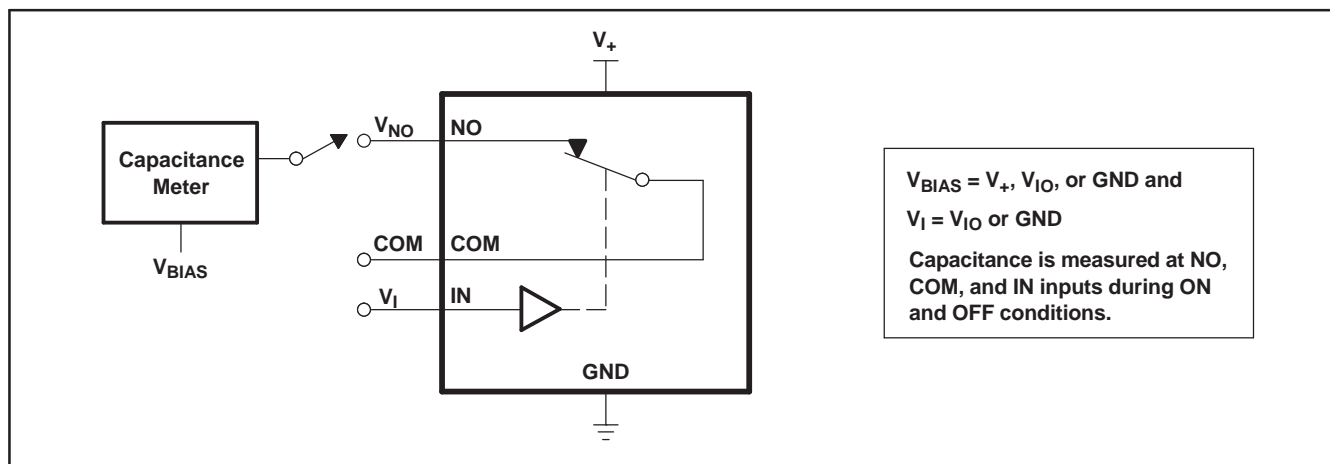
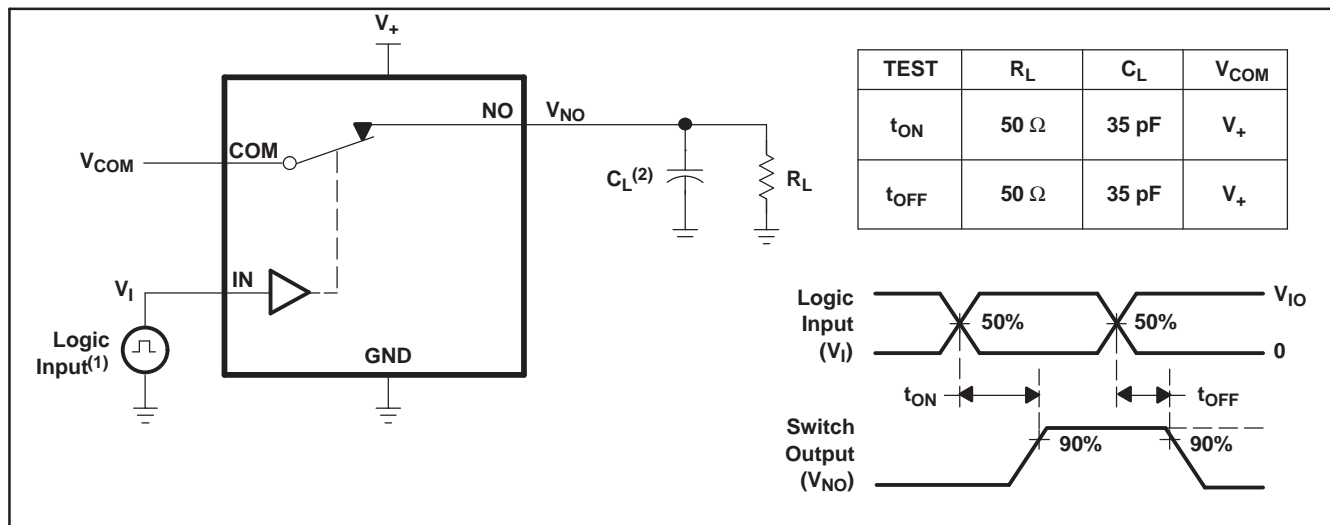

Figure 16. Capacitance ( $C_I$ ,  $C_{COM(OFF)}$ ,  $C_{COM(ON)}$ ,  $C_{NC(OFF)}$ ,  $C_{NC(ON)}$ )



(1) All input pulses are supplied by generators having the following characteristics: PRR  $\leq$  10 MHz,  $Z_O = 50 \Omega$ ,  $t_r < 5$  ns,  $t_f < 5$  ns.  
 (2)  $C_L$  includes probe and jig capacitance.

Figure 17. Turn-On ( $t_{ON}$ ) and Turn-Off Time ( $t_{OFF}$ )

PARAMETER MEASUREMENT INFORMATION (continued)

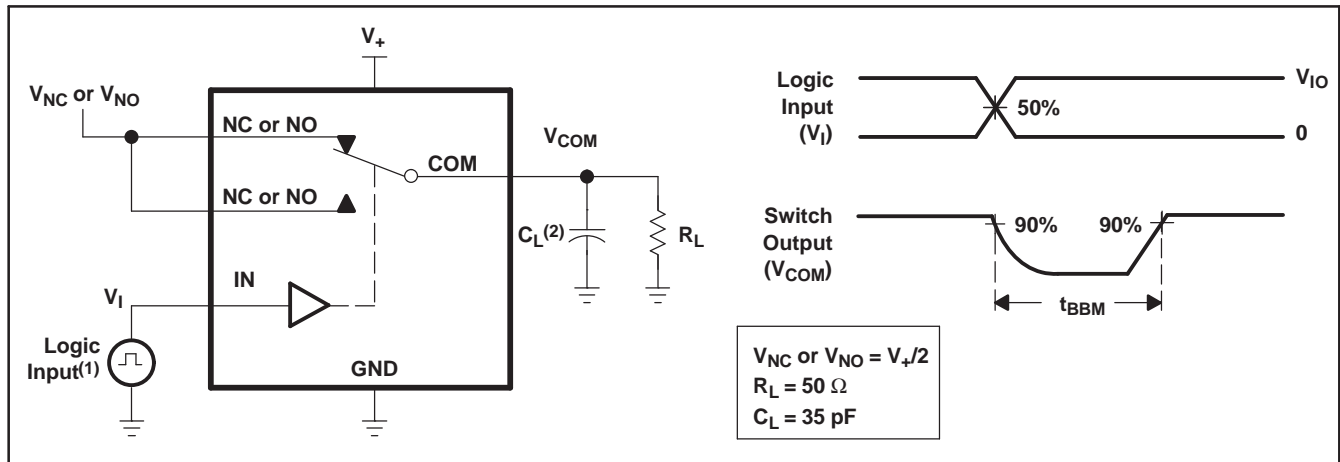

- (1) All input pulses are supplied by generators having the following characteristics: PRR ≤ 10 MHz, Z<sub>O</sub> = 50 Ω, t<sub>r</sub> < 5 ns, t<sub>f</sub> < 5 ns.
- (2) C<sub>L</sub> includes probe and jig capacitance.

Figure 18. Break-Before-Make Time (t<sub>BBM</sub>)

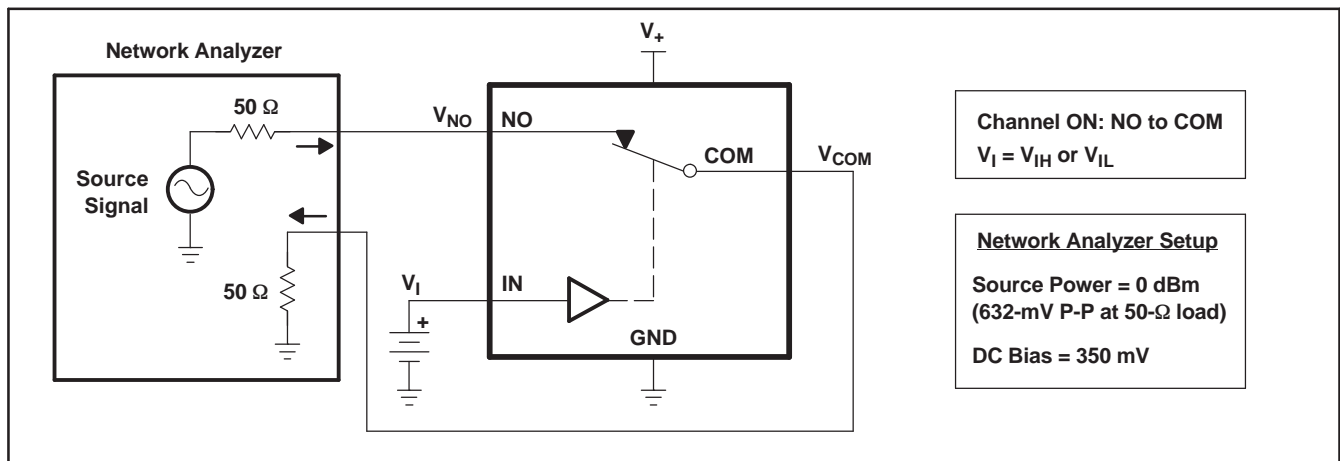

Figure 19. Bandwidth (BW)

PARAMETER MEASUREMENT INFORMATION (continued)

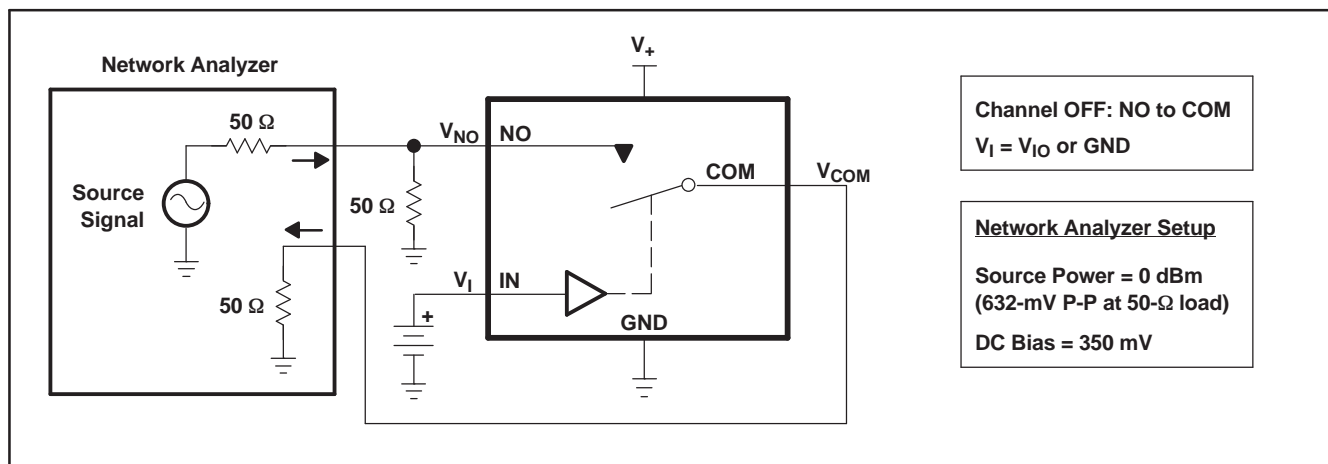

Figure 20. OFF Isolation ( $O_{ISO}$ )

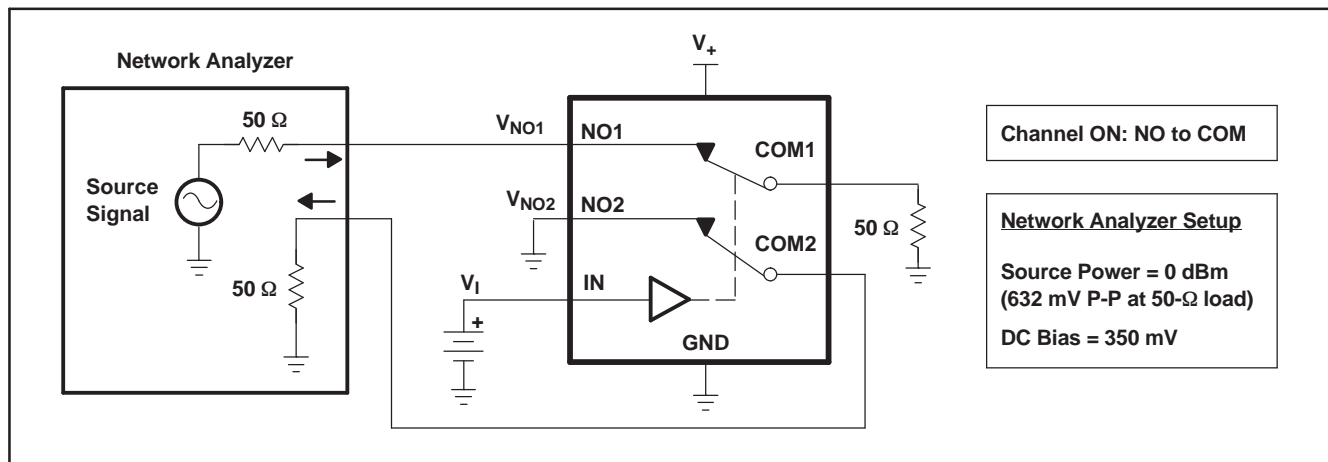
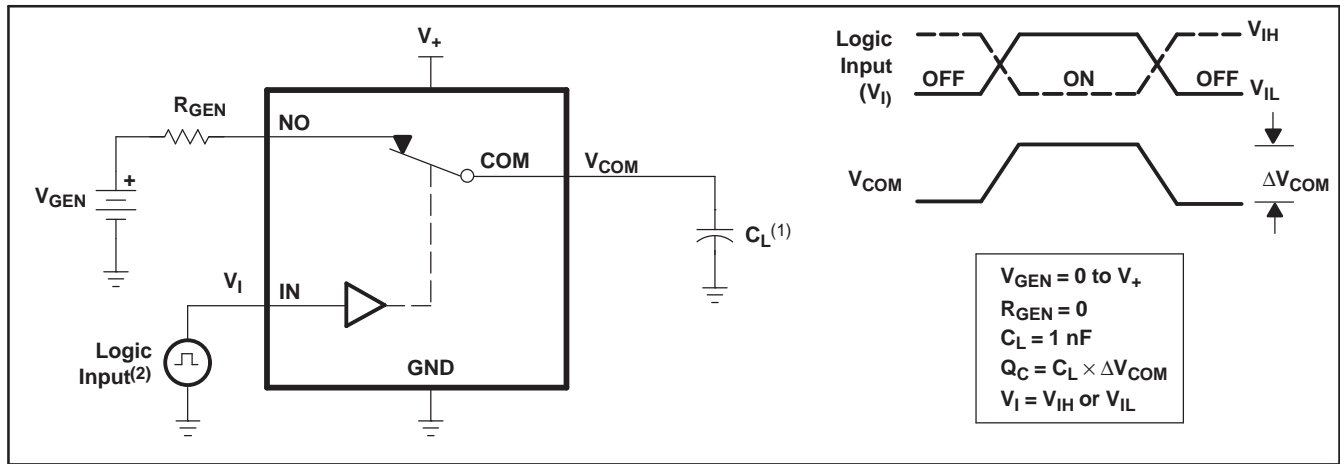

Figure 21. Crosstalk ( $X_{TALK}$ )

PARAMETER MEASUREMENT INFORMATION (continued)



(1)  $C_L$  includes probe and jig capacitance.

(2) All input pulses are supplied by generators having the following characteristics:  $PRR \leq 10 \text{ MHz}$ ,  $Z_O = 50 \Omega$ ,  $t_r < 5 \text{ ns}$ ,  $t_f < 5 \text{ ns}$ .

Figure 22. Charge Injection ( $Q_C$ )

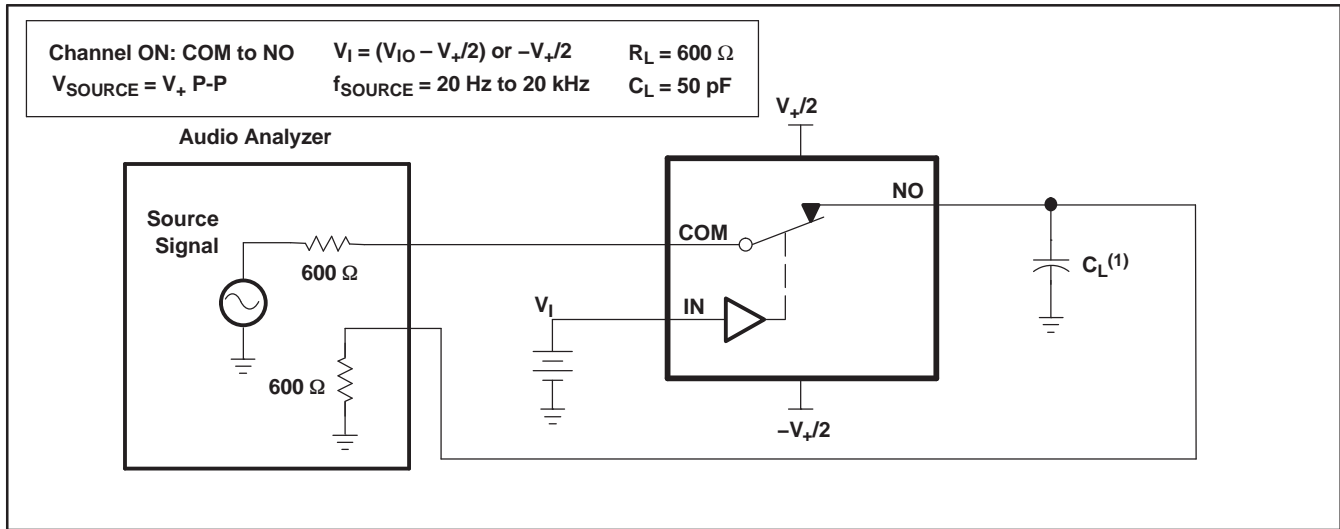

(1)  $C_L$  includes probe and jig capacitance.

Figure 23. Total Harmonic Distortion (THD)

**PACKAGING INFORMATION**

Orderable Device	Status <sup>(1)</sup>	Package Type	Package Drawing	Pins	Package Qty	Eco Plan <sup>(2)</sup>	Lead/Ball Finish	MSL Peak Temp <sup>(3)</sup>
TS3DS26227YZTR	ACTIVE	DSBGA	YZT	12	3000	Green (RoHS & no Sb/Br)	SNAGCU	Level-1-260C-UNLIM

<sup>(1)</sup> The marketing status values are defined as follows:

**ACTIVE:** Product device recommended for new designs.

**LIFEBUY:** TI has announced that the device will be discontinued, and a lifetime-buy period is in effect.

**NRND:** Not recommended for new designs. Device is in production to support existing customers, but TI does not recommend using this part in a new design.

**PREVIEW:** Device has been announced but is not in production. Samples may or may not be available.

**OBSOLETE:** TI has discontinued the production of the device.

<sup>(2)</sup> Eco Plan - The planned eco-friendly classification: Pb-Free (RoHS), Pb-Free (RoHS Exempt), or Green (RoHS & no Sb/Br) - please check <http://www.ti.com/productcontent> for the latest availability information and additional product content details.

**TBD:** The Pb-Free/Green conversion plan has not been defined.

**Pb-Free (RoHS):** TI's terms "Lead-Free" or "Pb-Free" mean semiconductor products that are compatible with the current RoHS requirements for all 6 substances, including the requirement that lead not exceed 0.1% by weight in homogeneous materials. Where designed to be soldered at high temperatures, TI Pb-Free products are suitable for use in specified lead-free processes.

**Pb-Free (RoHS Exempt):** This component has a RoHS exemption for either 1) lead-based flip-chip solder bumps used between the die and package, or 2) lead-based die adhesive used between the die and leadframe. The component is otherwise considered Pb-Free (RoHS compatible) as defined above.

**Green (RoHS & no Sb/Br):** TI defines "Green" to mean Pb-Free (RoHS compatible), and free of Bromine (Br) and Antimony (Sb) based flame retardants (Br or Sb do not exceed 0.1% by weight in homogeneous material)

<sup>(3)</sup> MSL, Peak Temp. -- The Moisture Sensitivity Level rating according to the JEDEC industry standard classifications, and peak solder temperature.

**Important Information and Disclaimer:**The information provided on this page represents TI's knowledge and belief as of the date that it is provided. TI bases its knowledge and belief on information provided by third parties, and makes no representation or warranty as to the accuracy of such information. Efforts are underway to better integrate information from third parties. TI has taken and continues to take reasonable steps to provide representative and accurate information but may not have conducted destructive testing or chemical analysis on incoming materials and chemicals. TI and TI suppliers consider certain information to be proprietary, and thus CAS numbers and other limited information may not be available for release.

In no event shall TI's liability arising out of such information exceed the total purchase price of the TI part(s) at issue in this document sold by TI to Customer on an annual basis.

**TAPE AND REEL INFORMATION**



**QUADRANT ASSIGNMENTS FOR PIN 1 ORIENTATION IN TAPE**



\*All dimensions are nominal

Device	Package Type	Package Drawing	Pins	SPQ	Reel Diameter (mm)	Reel Width W1 (mm)	A0 (mm)	B0 (mm)	K0 (mm)	P1 (mm)	W (mm)	Pin1 Quadrant
TS3DS26227YZTR	DSBGA	YZT	12	3000	178.0	8.4	1.49	1.99	0.75	4.0	8.0	Q2
TS3DS26227YZTR	DSBGA	YZT	12	3000	180.0	8.4	1.5	2.03	0.7	4.0	8.0	Q2
TS3DS26227YZTR	DSBGA	YZT	12	3000	180.0	8.4	1.5	2.03	0.7	4.0	8.0	Q2



**TAPE AND REEL BOX DIMENSIONS**



\*All dimensions are nominal

Device	Package Type	Package Drawing	Pins	SPQ	Length (mm)	Width (mm)	Height (mm)
TS3DS26227YZTR	DSBGA	YZT	12	3000	220.0	220.0	35.0
TS3DS26227YZTR	DSBGA	YZT	12	3000	220.0	220.0	34.0
TS3DS26227YZTR	DSBGA	YZT	12	3000	220.0	220.0	34.0

YZT (R-XBGA-N12)

(CUSTOM) DIE-SIZE BALL GRID ARRAY

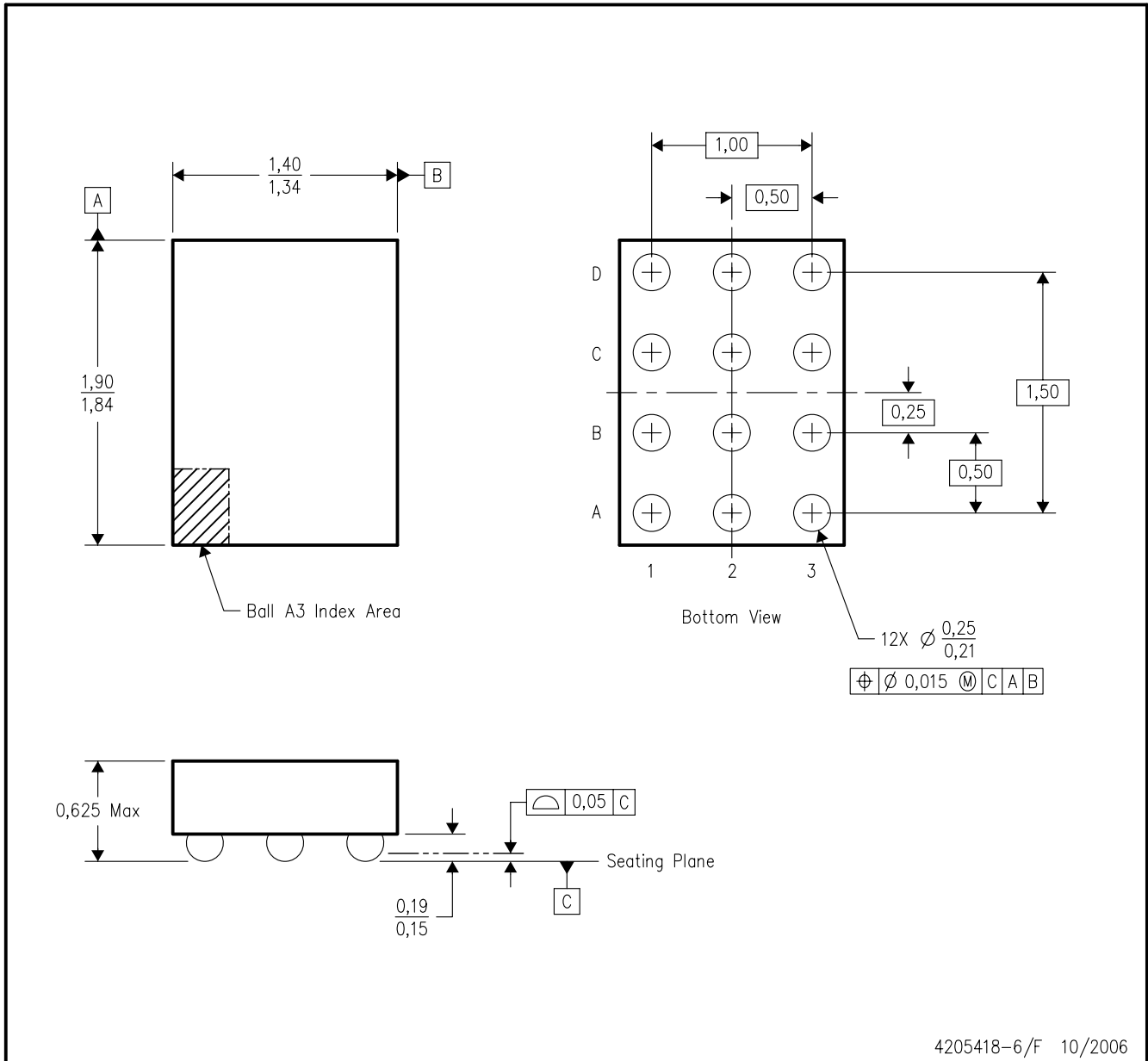

- NOTES:
- A. All linear dimensions are in millimeters. Dimensioning and tolerancing per ASME Y14.5M-1994.
  - B. This drawing is subject to change without notice.
  - C. NanoFree™ package configuration.
  - D. This is a lead-free solder ball design.

## IMPORTANT NOTICE

Texas Instruments Incorporated and its subsidiaries (TI) reserve the right to make corrections, modifications, enhancements, improvements, and other changes to its products and services at any time and to discontinue any product or service without notice. Customers should obtain the latest relevant information before placing orders and should verify that such information is current and complete. All products are sold subject to TI's terms and conditions of sale supplied at the time of order acknowledgment.

TI warrants performance of its hardware products to the specifications applicable at the time of sale in accordance with TI's standard warranty. Testing and other quality control techniques are used to the extent TI deems necessary to support this warranty. Except where mandated by government requirements, testing of all parameters of each product is not necessarily performed.

TI assumes no liability for applications assistance or customer product design. Customers are responsible for their products and applications using TI components. To minimize the risks associated with customer products and applications, customers should provide adequate design and operating safeguards.

TI does not warrant or represent that any license, either express or implied, is granted under any TI patent right, copyright, mask work right, or other TI intellectual property right relating to any combination, machine, or process in which TI products or services are used. Information published by TI regarding third-party products or services does not constitute a license from TI to use such products or services or a warranty or endorsement thereof. Use of such information may require a license from a third party under the patents or other intellectual property of the third party, or a license from TI under the patents or other intellectual property of TI.

Reproduction of TI information in TI data books or data sheets is permissible only if reproduction is without alteration and is accompanied by all associated warranties, conditions, limitations, and notices. Reproduction of this information with alteration is an unfair and deceptive business practice. TI is not responsible or liable for such altered documentation. Information of third parties may be subject to additional restrictions.

Resale of TI products or services with statements different from or beyond the parameters stated by TI for that product or service voids all express and any implied warranties for the associated TI product or service and is an unfair and deceptive business practice. TI is not responsible or liable for any such statements.

TI products are not authorized for use in safety-critical applications (such as life support) where a failure of the TI product would reasonably be expected to cause severe personal injury or death, unless officers of the parties have executed an agreement specifically governing such use. Buyers represent that they have all necessary expertise in the safety and regulatory ramifications of their applications, and acknowledge and agree that they are solely responsible for all legal, regulatory and safety-related requirements concerning their products and any use of TI products in such safety-critical applications, notwithstanding any applications-related information or support that may be provided by TI. Further, Buyers must fully indemnify TI and its representatives against any damages arising out of the use of TI products in such safety-critical applications.

TI products are neither designed nor intended for use in military/aerospace applications or environments unless the TI products are specifically designated by TI as military-grade or "enhanced plastic." Only products designated by TI as military-grade meet military specifications. Buyers acknowledge and agree that any such use of TI products which TI has not designated as military-grade is solely at the Buyer's risk, and that they are solely responsible for compliance with all legal and regulatory requirements in connection with such use.

TI products are neither designed nor intended for use in automotive applications or environments unless the specific TI products are designated by TI as compliant with ISO/TS 16949 requirements. Buyers acknowledge and agree that, if they use any non-designated products in automotive applications, TI will not be responsible for any failure to meet such requirements.

Following are URLs where you can obtain information on other Texas Instruments products and application solutions:

### Products

Amplifiers	<a href="http://amplifier.ti.com">amplifier.ti.com</a>
Data Converters	<a href="http://dataconverter.ti.com">dataconverter.ti.com</a>
DSP	<a href="http://dsp.ti.com">dsp.ti.com</a>
Clocks and Timers	<a href="http://www.ti.com/clocks">www.ti.com/clocks</a>
Interface	<a href="http://interface.ti.com">interface.ti.com</a>
Logic	<a href="http://logic.ti.com">logic.ti.com</a>
Power Mgmt	<a href="http://power.ti.com">power.ti.com</a>
Microcontrollers	<a href="http://microcontroller.ti.com">microcontroller.ti.com</a>
RFID	<a href="http://www.ti-rfid.com">www.ti-rfid.com</a>
RF/IF and ZigBee® Solutions	<a href="http://www.ti.com/lprf">www.ti.com/lprf</a>

### Applications

Audio	<a href="http://www.ti.com/audio">www.ti.com/audio</a>
Automotive	<a href="http://www.ti.com/automotive">www.ti.com/automotive</a>
Broadband	<a href="http://www.ti.com/broadband">www.ti.com/broadband</a>
Digital Control	<a href="http://www.ti.com/digitalcontrol">www.ti.com/digitalcontrol</a>
Medical	<a href="http://www.ti.com/medical">www.ti.com/medical</a>
Military	<a href="http://www.ti.com/military">www.ti.com/military</a>
Optical Networking	<a href="http://www.ti.com/opticalnetwork">www.ti.com/opticalnetwork</a>
Security	<a href="http://www.ti.com/security">www.ti.com/security</a>
Telephony	<a href="http://www.ti.com/telephony">www.ti.com/telephony</a>
Video & Imaging	<a href="http://www.ti.com/video">www.ti.com/video</a>
Wireless	<a href="http://www.ti.com/wireless">www.ti.com/wireless</a>

Mailing Address: Texas Instruments, Post Office Box 655303, Dallas, Texas 75265  
Copyright © 2008, Texas Instruments Incorporated